

F.切口形插入襯套

F.FIXED RENEWABLE BUSH

內徑

分精密級、一般級和鉸刀用3種

I.D.

Made in 3 different tolerances for precise drilling, normal drilling and reaming.

外徑

以內徑為基準，經精密研磨加工而成，分固定式襯套及插入式襯套

O.D.

Highly precise finish based on I.D.
(Press Fit Bush...P6) (Renewable Bush...m5)

硬度

HRC60° 以上耐磨度極高

HARDNESS

HRC 60° up for long-er life.

襯套 BUSH

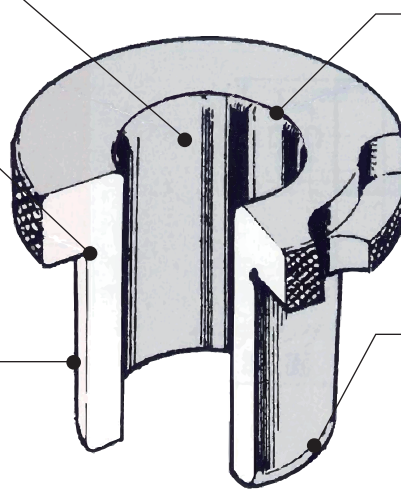

R圓

提供容易滑入之引導作用

RADIUS

For smooth entry of tool.

倒角

為了襯套之容易裝配故施以倒角加工

CHAMFER

Permit easy entry and removal.

治具用襯套 TYPE

形狀及種類 TYPE AND APPLICATION

S...精密鉗頭用

R...鉸刀用

S...Precise drilling R...Reaming

名稱 Designation	固定襯套 Press Fit		插入式襯套 Renewable Bush				引導用 固定式襯套 Headless Liner bush	止動螺絲 Lock Screw	止動環 Round Clamp	
	無帽緣 Headless	付帽緣 Headed	圓形 Round	右向迴轉切口形 Right Slip	左向迴轉切口形 Left Slip	切口形 Fixed				
形狀 Shape										
內徑的 使用 Sort of I.D.	精密級鉗頭 Precise Drilling	SA	SB	SC	SD	SE	SF	G 形	T 形	R 形
	一般級鉗頭 Normal Drilling	A	B	C	D	E	F			
	鉸刀 Reaming	-	BR	CR	DR	ER	FR			
使用方法 Illustration of use	無帽緣(A) Headless		無帽緣(B) Headed		插入式(C)	插入式(D)	插入式(E)	插入式(F)		
	AB型襯套均以緊密配合平均壓入 Press the bush into the plate				先將固定襯套G以緊密配合壓入治具板後再用手裝取插入式襯套並配以T形螺絲固定 First press the liner bush into the plate, the insert the bush and set the lock screw.					

內徑與外徑的同心度 Concentricity of ID and OD

內徑 (d) 寸法 ID(d)	1.6~18.0	18.1~50.0	50.1~55.0
精密級 / 鉗孔 Precise drilling/ reaming	0.005	0.008	0.010
一般級 Normal Drilling	0.012	0.020	0.025

與治具板之裝配公差 Assembly tolerance with bush plate

襯套承板的內徑尺寸 I.D.(d) of hole in bush plate	0.3~3.0	3.1~6.0	6.1~10.0	10.1~18.0	18.1~30.0	30.1~50.0	50.1~55.0
H7公差 Tolerance H7	+0.010 0	+0.012 0	+0.015 0	+0.018 0	+0.021 0	+0.025 0	+0.030 0

F.切口形插入襯套

F.FIXED RENEWABLE BUSH

- 切口形插入襯套，請置入引導式固定襯套使用(G形)。
- 切口形插入襯套的外徑(D)和引導用固定式襯套的內徑(d)請用同尺寸。
- F形襯套在下列的時機使用最相宜。
- Left slip renewable bush must be used in combination with headless liner bush (Type G).
- O.D. (D) of left slip renewable bush must coincide with I.D.(d) of headless liner bush.
- The bush can be frequently used in case the same products are made in quantity for long period.

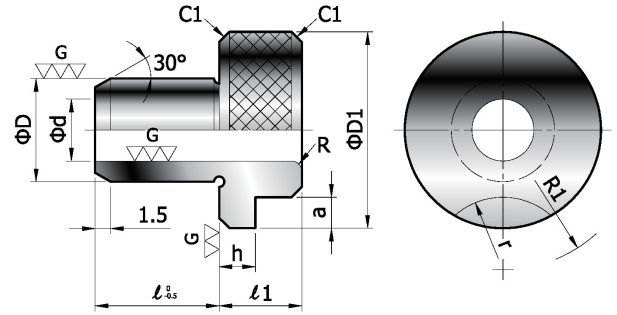

訂購例: Order

SF - 10.0 x 20

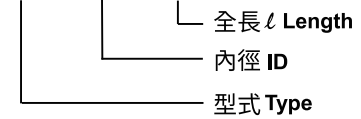

■ 標準稱呼尺寸(標準尺寸以外亦可製作)
Standard dimensions (Special dimensions be ordered)

Ød(內徑) (ID)	ØD(外徑)(OD) m5	ØD1	l_1	h	a	R	R1	r	止動螺絲 Lock Screw	精密級 一般級	Precise Norma	l
1.6~2.0	8	+0.012 +0.006	16	8	3.5	3	0.8	7	M5	SF	10 • 12	
2.1~3.0							12			F		
3.1~4.0							1			SF		
4.1~6.0	10	+0.015 +0.007	19	9	3	1	13.5	9	M6	SF	12 • 16	
6.1~8.0	15						15			F		
8.1~10.0	18						17			SF		
10.1~12.0	18	+0.017 +0.008	30	12	5	4	19	10	M8	SF	16 • 20	
12.1~15.0	22						22			F		
15.1~18.0	26						24.5			SF		
18.1~22.0	30	+0.020 +0.009	47	15	6	5	28	10	M8	SF	20 • 25	
22.1~26.0	35						33			F		
26.1~30.0	42						36.5			SF		
30.1~35.0	48	+0.024 +0.011	69	15	6	5	40	10	M8	SF	25 • 30	
35.1~42.0	55						44			F		
										SF		

■ 內徑(d)的製作公差 Tolerance of I.D. (d)

內徑(d) 寸法	1.6~3.0	3.1~6.0	6.1~10.0	10.1~18.0	18.1~30.0	30.1~42.0
SF (G6)	+0.008 +0.002	+0.012 +0.004	+0.014 +0.005	+0.017 +0.006	+0.020 +0.007	+0.025 +0.009
F	+0.025 +0.002	+0.030 +0.004	+0.036 +0.005	+0.043 +0.006	+0.052 +0.007	+0.062 +0.009
FR	+0.014 +0.008	+0.020 +0.012	+0.024 +0.015	+0.029 +0.018	+0.034 +0.021	+0.041 +0.025

